

Social Distancing Dividers

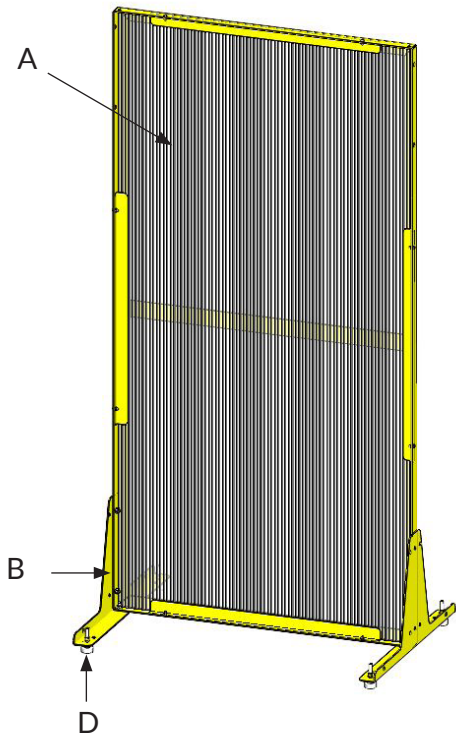

Tool List

1/2" wrench

Ratchet with 1/2" socket, or impact driver with 1/2" socket

Part # WPS3672 - Work Partition 72"h x 26"d x 36"w ,

WPS4872 - Work Partition 72"h x 26"d x 36"w

Item	Components	Qty
A	Panel frame assembly	1
B	Leg support	2
C	Top tie plate	1
D	Leveler feet	4
E	5/16-18 x 1" hex head cap screw	6
F	5/16" flat washer	8
G	5/16" lock washer	10
H	5/16-18 hex nut	10

*Additional hardware supplied for joining frames side by side

- 1 Attach leveler feet (D) to leg support (B) (Fig-1a). Replace leveler feet with casters for extra mobility (Fig-1b). Attach leg support (B) to the panel frame assembly (A) using a 5/16-18 x 1" hex head cap screw (E), 5/16" flat washers (F), 5/16" lock washers (G), and 5/16-18 hex nuts (H).

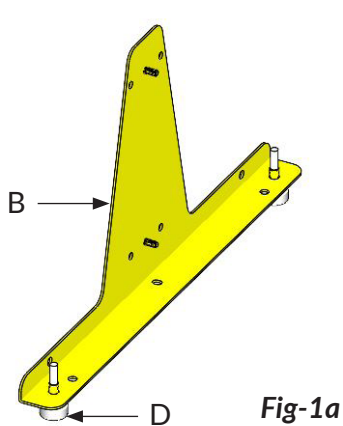

Fig-1a

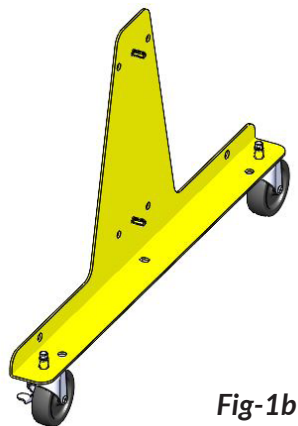

Fig-1b

Part# WPSMCK - Mobile Caster Kit, Set of (4)

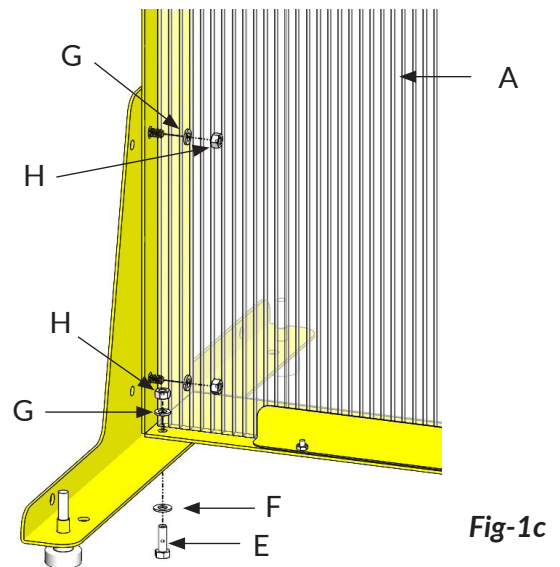

Fig-1c

Social Distancing Dividers

- 2** Join two frames side by side:
Place two frames together with two leg supports pressed against each other. Use 5/16-18 x 1" hex head cap screws (E), 5/16" flat washers (F), 5/16" lock washers (G), and 5/16-18 hex nuts (H) to connect two leg supports at front and back (Fig-2a). Use a top tie plate (C), 5/16-18 x 1" hex head cap screws (E), 5/16" flat washers (F), 5/16" lock washers (G), and 5/16-18 hex nuts (H) to connect the frames at the top (Fig-2b).

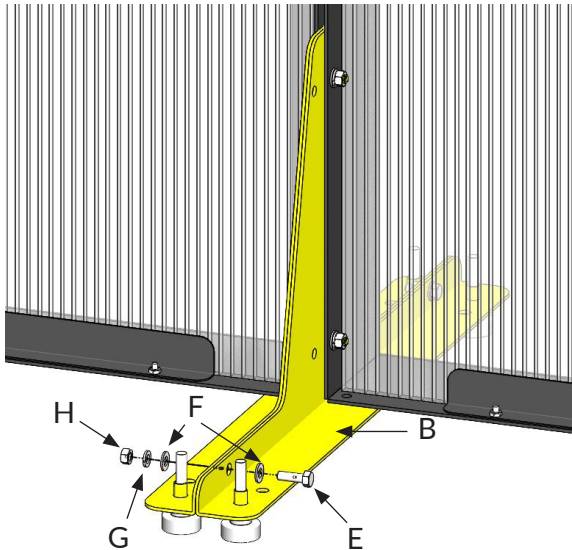

Fig-2a

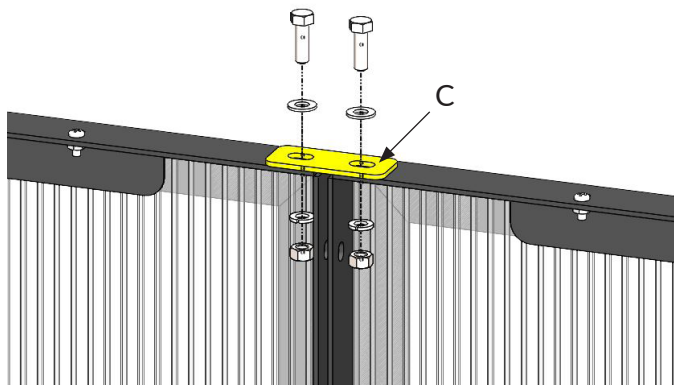

Fig-2b

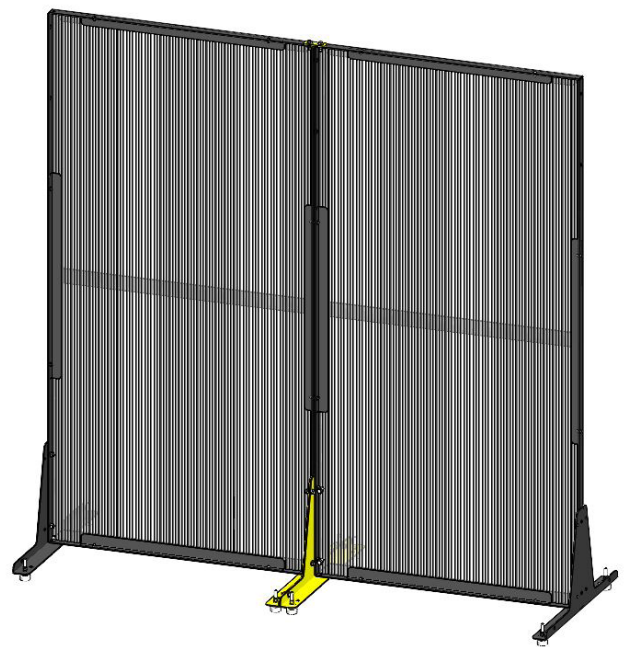

Fig-2c

Social Distancing Dividers

- 3** Join two frames at corners:
 Remove one leg from a frame and place it at a 90-degree angle with another frame. Use a corner joining bracket (I), 5/16-18 x 1" hex head cap screws (E), 5/16" flat washers (F), 5/16" lock washers (G), and 5/16-18 hex nuts (H) to join the two frames at the bottom (Fig-3a). Use the top tie plate (C), 5/16-18 x 1" hex head cap screws (E), 5/16" flat washers (F), 5/16" lock washers (G), and 5/16-18 hex nuts (H) to join two frames at the top (Fig-3b).

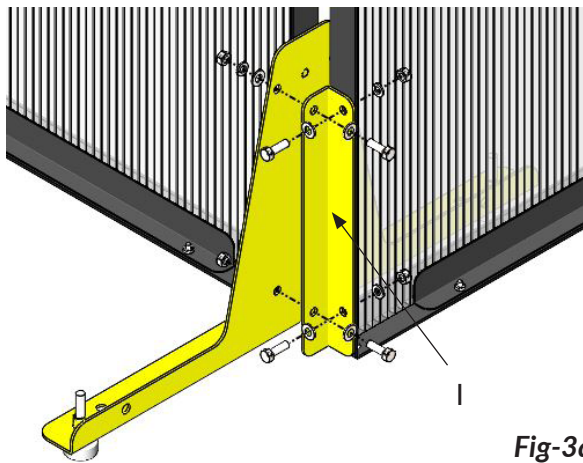

Fig-3a

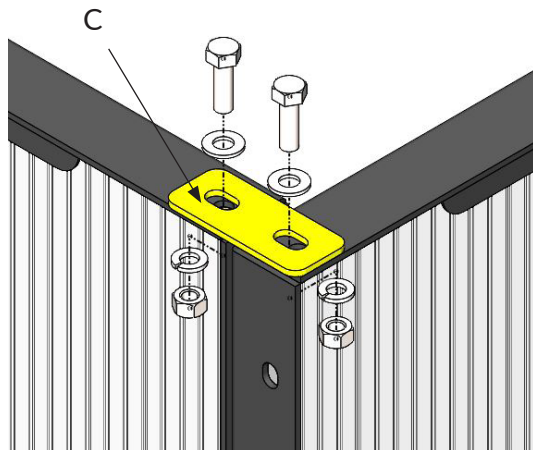

Fig-3b

Part # WPSCJK - Corner Joining Kit

Item	Components	Qty
I	Corner joining bracket	1
E	5/16-18 x 1" hex head cap screw	2
F	5/16" flat washer	2
G	5/16" lock washer	2
H	5/16-18 hex nut	2

*Additional hardware supplied with the frames will be used in corner assembly.

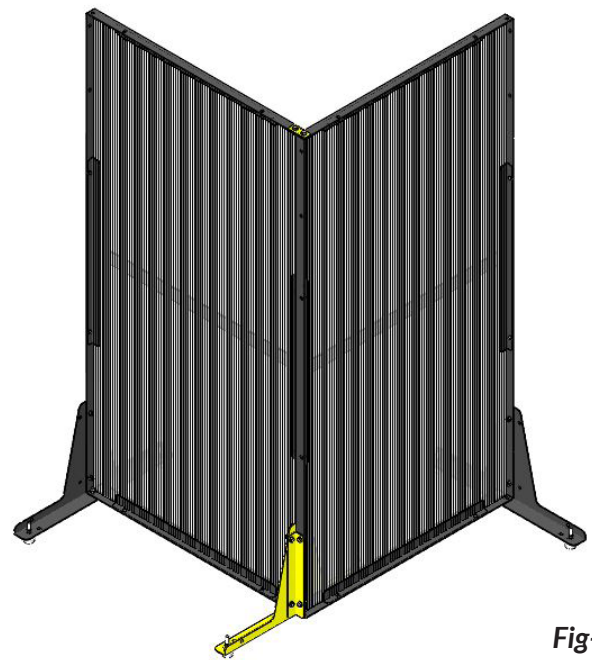

Fig-3c